

Material Specification:

39mm

Mat: 111mm
Slit Width

Straightness: 1.5mm per 1m
Twist: 2mm per 1m

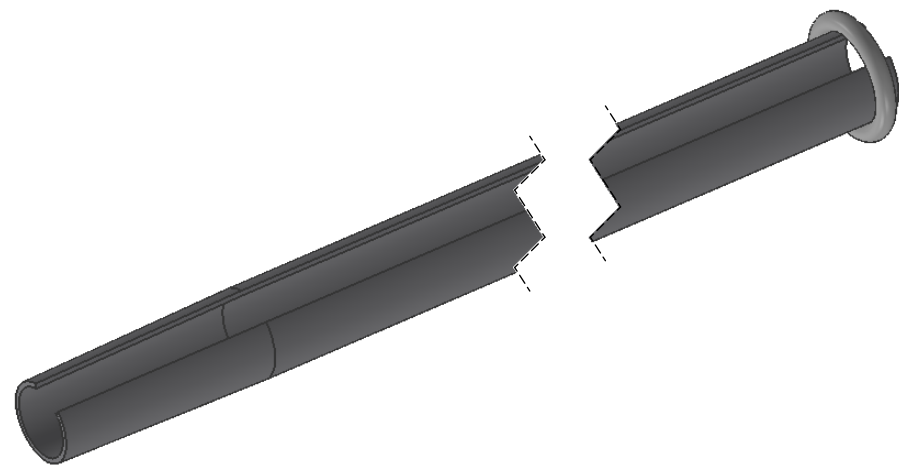

Material: **Supraform S420MC/EN10149**

Remove all sharp corners and burrs.

Original Sheet A3

Unless otherwise noted tolerances on machined parts will be according to the following decimal place system:
X : 1mm
X.X : 0.25mm
X.XX : 0.10mm

Approved
Date

Title
Split Set Type Ø39

Scale	Stock Code	Drawing Number	Rev.
Drawn			
Date			